



SMOKER
CHS052E
 Static oven with
 external smoking
 device

**CONSTRUCTION
 FEATURES**

- Tightness chamber with radiused corners
- Total thermic insulation with rock or glass wool
- Long lasting frontal seals made up of food grade of high heat resistance
- Static heating provided by low consumption wire heating element that coils up all the chamber
- Snap-shut door
- Mounted on four 125mm diameter castors, two of which with brake
- All-around rubber bumpers
- Tightness cavity with radiused corners, built-in drip tray and drainage system

**FUNCTIONAL
 FEATURES**

- Electronic control panel of temperature, time, core probe, Δt and smoking with LCD touch-screen
- Operating temperature 30°C - 160°C
- End-of-cycle buzzer
- Chamber with safety thermostat
- Internal drain for easy cleaning
- Condensation drain tray
- Delayed start timer

**STANDARD
 SUPPLY**

- Multipoint core probe with the possibility to register 30 different temperatures and save them in the HACCP report (available only with USB port device)
- Glazed door plus lighting
- Removable GN 2/1 and GN 1/1 tray racks
- External stainless steel smoke generator with ash tray
- USB port saving device HACCP

**OPTIONS
 & ACCESSORIES**

- | | |
|--|--|
| <input type="checkbox"/> EcoWash cleaning system | <input type="checkbox"/> Water filter system |
| <input type="checkbox"/> Opposite side opening | <input type="checkbox"/> Hooks kit |
| <input type="checkbox"/> Grids | <input type="checkbox"/> Bag of wooden chips |
| <input type="checkbox"/> Trays | <input type="checkbox"/> Detergent/Rinsing agent |

MODULINESRL

Via dell'Industria 11, Z.I. San Giacomo di Veglia 31029 Vittorio Veneto (TV) - ITALY
 tel. +39 0438 5063 - fax +39 0438 912 323 - info@moduline.it - www.moduline.it



moduline

TECHNICAL INSTALLATION DIAGRAM

Electricity supply
cable inlet 

Smoke exhaustion
vent 

Chamber drain 

Important - Drawing and
dimensions refer to the
standard version.
They may change with the
addition of accessories or
options.

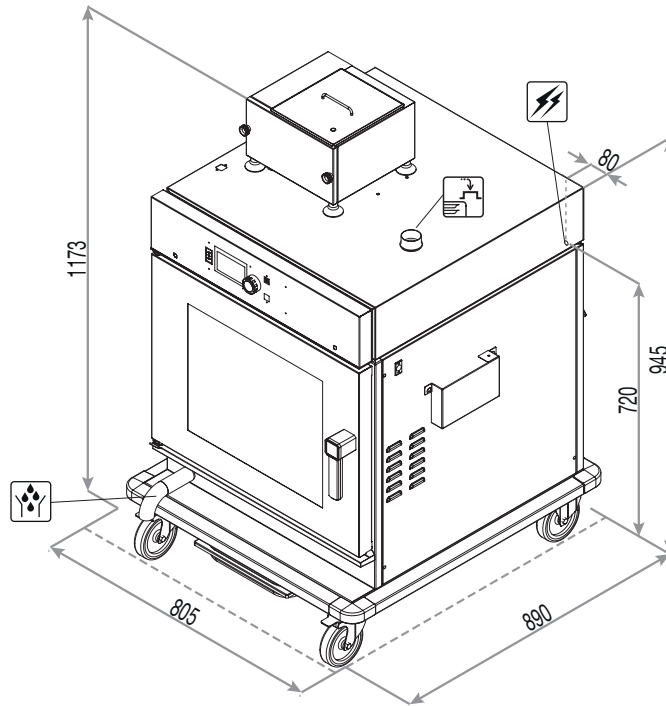

Overall dimensions
(W x D x H) - mm

805 x 890 x 1173h

Power supply

AC 220-240V 50/60Hz

Total input
[kW]

3,15 (230V)

Amps.
[A]

13,7 (230V)

Working
temperature [°C]

30 ÷ 160

Trays capacity -
distance [mm]

5 x GN 2/1 - (75)
10 x GN 1/1 - (75)

Product max
capacity [Kg]

46

Net weight
[Kg]

87

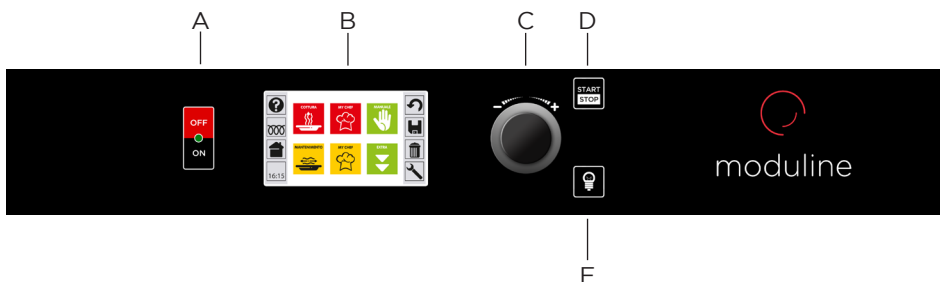

- A ON/OFF switch
- B Display Touch Screen
- C Setting knob and select "ENTER"
- D "START/STOP" button
- E Chamber light button

MODULINESRL

Via dell'Industria 11, Z.I. San Giacomo di Veglia 31029 Vittorio Veneto (TV) - ITALY
tel. +39 0438 5063 - fax +39 0438 912 323 - info@moduline.it - www.moduline.it