



COOK & HOLD CHT281E

Static low
 temperature oven

CONSTRUCTION FEATURES

- Two separately controlled compartments
- All-around rubber bumpers
- Total thermic insulation with rock or glass wool
- Long lasting front seal, made up of food-grade and high-heat resistant silicone
- Removable side racks to facilitate cleaning
- Static heating provided by low consumption wire heating element that coils up all the chamber
- Ergonomic and fully built-in door handles with magnetic closure
- Mounted on four 150 mm diameter castors, two of which with brake
- Ergonomic handle for pushing and guiding
- Easy access to facilitate maintenance and repair
- Opposite side opening

FUNCTIONAL FEATURES

- Two separate electronic controls
- Operating temperature 30° ÷ 120°C
- Adjustable humidity vents on the doors
- Chamber with safety thermostat
- Manual keyboard lock

STANDARD SUPPLY

- Removable GN 1/1 tray racks
- Internal core probe

OPTIONS & ACCESSORIES

- Kit feet
- Grids
- Trays



moduline

TECHNICAL INSTALLATION DIAGRAM

Electricity supply
cable inlet 

Vent for excess
humidity 

Important - Drawing and
dimensions refer to the
standard version.
They may change with the
addition of accessories
or options.

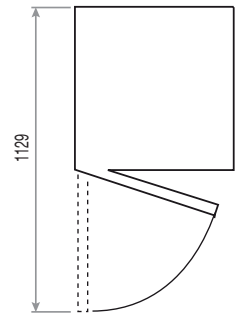
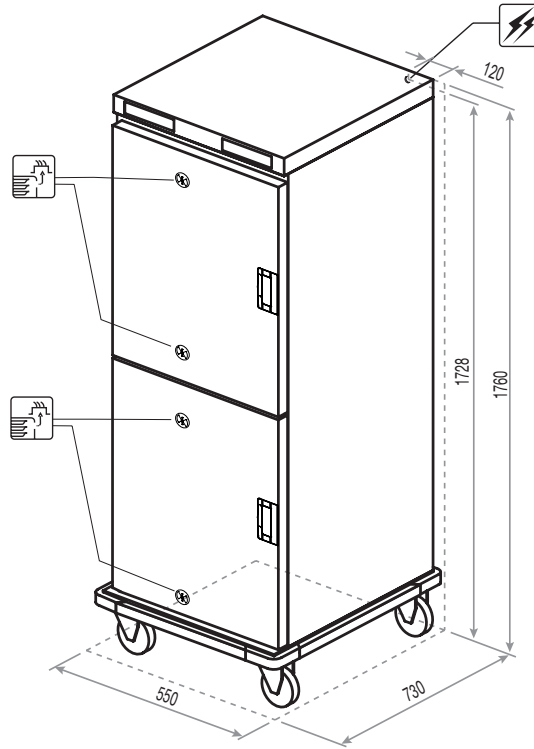

Overall dimensions
(W x D x H) - mm

550 x 730 x 1760h

Trays capacity -
distance [mm]

(8+8) x GN 1/1 - (75)

Tray max. height
[mm]

8 x 65 (h) + 8 x 65 (h)
3 x 150 (h) + 3 x 150 (h)
2 x 200 (h) + 2 x 65 (h) and 2 x 200 (h) + 2 x 65 (h)

Power supply

AC 220-240V 50/60Hz

Total input
[kW]

2 (230V)

Amps.
[A]

8,7 (230V)

Working
temperature [°C]

30 ÷ 120

Product max
capacity [Kg]

44

Net weight
[Kg]

94

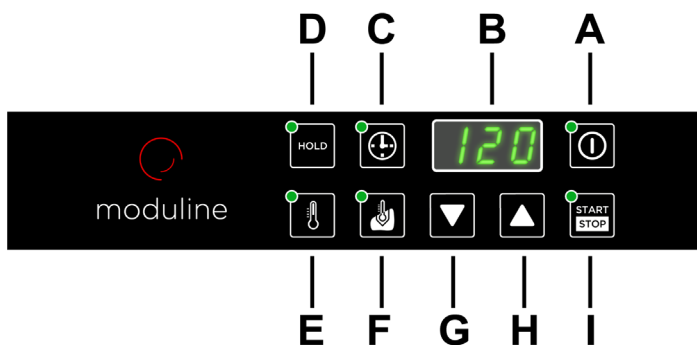

- A ON/OFF switch
- B Display
- C Time selection key
- D Keeping warm key
- E Temperature selection key
- F Core probe on/off key
- G Temperature decrease key
- H Temperature increase key
- I START/STOP key

MODULINESRRL

Via dell'Industria 11, Z.I. San Giacomo di Veglia 31029 Vittorio Veneto (TV) - ITALY
tel. +39 0438 5063 - fax +39 0438 912 323 - info@moduline.it - www.moduline.it