

item #
 model #
 project #
 sis #
 aia #

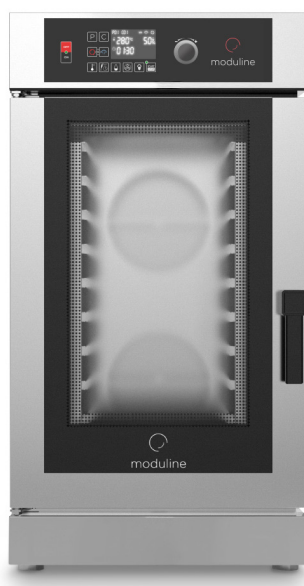

COMBI GCE110D Combi oven

CONSTRUCTION FEATURES

- Tightness chamber with radiused corners
- Total thermic insulation with rock or glass wool
- Long lasting front seals made up of food grade of high heat resistance
- Removable side racks to facilitate cleaning
- Internal drain for easy cleaning
- Ventilated heating provided by high efficiency protected heating elements
- Snap-shut door
- Adjustable feet
- Easy access to facilitate maintenance and repair
- Double low-emission glass door with internal ventilation
- Openable inside glass of the door
- Condensation drip tray under the door and connected to the oven drainage system.

FUNCTIONAL FEATURES

- Elettronic control panel with digital display, keys and knob
- Simplified, user-friendly controls
- Periodic reversal of direction of rotation of the fan for better air distribution
- Automatic stopping of fans when the door is opened
- End-of-cycle buzzer
- Chamber with safety thermostat
- Operating temperature: from 30°C to 280°C in Convection mode, from 30°C to 280°C in Mixed Steam - Convection mode, from 30°C to 130°C in Direct Steam mode
- The cooking program can be divided into different phases
- Automatic humidity exhaust system after cooking
- Self-diagnosis system
- Steam condensation system
- Chamber cooling program
- IdealWarm function: the intelligent temperature decrease in the cavity at the end of the cooking cycle allows perfect warm holding
- Climachef system
- FlashDry instant dehumidification function of the chamber.
- PadLock: key lock system with password
- ProTime system allows you to set the date and the time you want the oven to preheat or start working.
- Glazed door plus lighting
- Removable GN1/1 tray racks

OPTIONS & ACCESSORIES

- | | | |
|--|--|--|
| <input type="checkbox"/> Supports | <input type="checkbox"/> USB port | <input type="checkbox"/> Trays |
| <input type="checkbox"/> Multipoint core probe | <input type="checkbox"/> SpeedGrade fan speed adjustment | <input type="checkbox"/> Sound silencer |
| <input type="checkbox"/> Needle core probe, thin | <input type="checkbox"/> Water filter system | <input type="checkbox"/> Air condensation hood |
| <input type="checkbox"/> External hand shower | <input type="checkbox"/> Grids | <input type="checkbox"/> Opposite side opening |
| | | <input type="checkbox"/> Door lock with key |





MODULINESRL

Via dell'Industria 11, Z.I. San Giacomo di Veglia 31029 Vittorio Veneto (TV) - ITALY
 tel. +39 0438 5063 - fax +39 0438 912 323 - info@moduline.it - www.moduline.it



moduline

TECHNICAL INSTALLATION DIAGRAM

- Electricity supply cable inlet 
- Safety vent humidity 
- Chamber drain 
- Softened water inlet 
- Adjustable vent for excess humidity 

Important - Drawing and dimensions refer to the standard version. They may change with the addition of accessories or options.

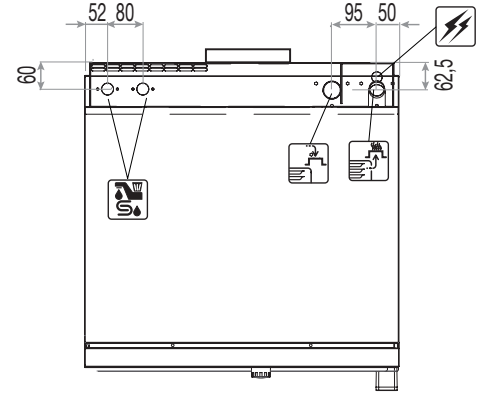
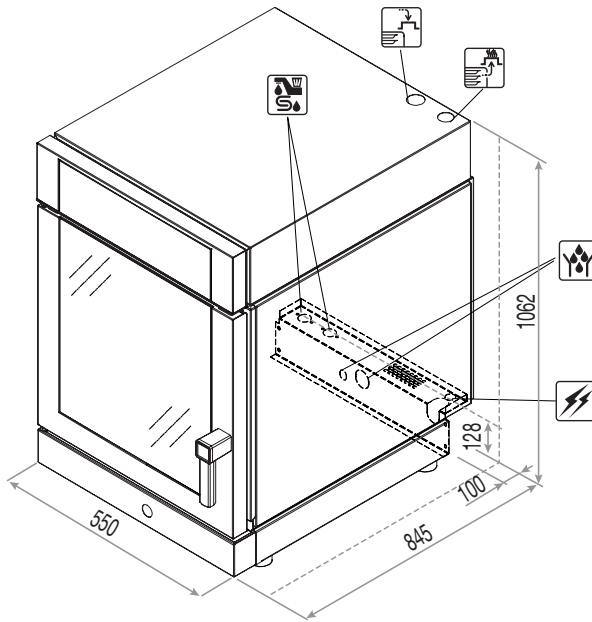

Overall dimensions (W x D x H) - mm	550 x 845 x 1062h	Product max capacity [Kg]	24
Trays capacity	10 x GN 1/1	Total input [kW]	12,5 (400V)
Distance [mm]	64	Amps. [A]	18,1 (400V)
Power supply	380-415V 3N 50/60Hz	Water pressure [kPa]	150 ÷ 500
Working temperature [°C]	30 ÷ 280	Net weight [Kg]	100

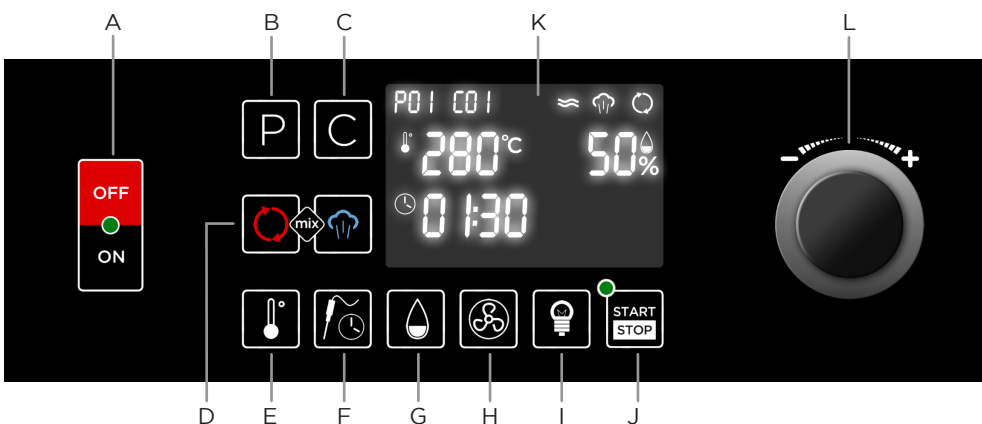

- A ON/OFF switch
- B Program and back key
- C Cycle key
- D Cooking mode key
- E Cavity temperature key
- F Probe / Time key
- G Humidity key
- H Fan speed key
- I Light key
- J START/STOP key
- K Digital display
- L Knob to set and enter key

MODULINESRL

Via dell'Industria 11, Z.I. San Giacomo di Veglia 31029 Vittorio Veneto (TV) - ITALY
tel. +39 0438 5063 - fax +39 0438 912 323 - info@moduline.it - www.moduline.it