

item #
model #
project #
sis #
aia #



HOLD HFT162E

Ventilated cold
holding cabinet

CONSTRUCTION FEATURES

- Chamber with radiused corners and removable side racks to facilitate cleaning
- All-around rubber bumpers
- Highly efficient and thick insulation, casing injected with CFC-free polyurethane foam
- Ergonomic and fully built-in door handles with magnetic closure
- Cooling process through monobloc cooling unit with evaporator
- Environmentally sustainable monobloc cooling unit with gas R290
- Mounted on four 150mm diameter castors, two of which with brake
- Ergonomic handles for pushing and guiding
- Easy access to facilitate maintenance and repair

FUNCTIONAL FEATURES

- Electronic temperature control with defrosting programme
- Simplified, user-friendly controls
- Operating temperature -18°C / +5°C

STANDARD SUPPLY

- Removable GN2/1 and GN1/1 tray racks

OPTIONS & ACCESSORIES

- Grids
- Trays

MODULINESRL

Via dell'Industria 11, Z.I. San Giacomo di Veglia 31029 Vittorio Veneto (TV) - ITALY
tel. +39 0438 5063 - fax +39 0438 912 323 - info@moduline.it - www.moduline.it



moduline

TECHNICAL INSTALLATION DIAGRAM

Electricity supply
cable inlet

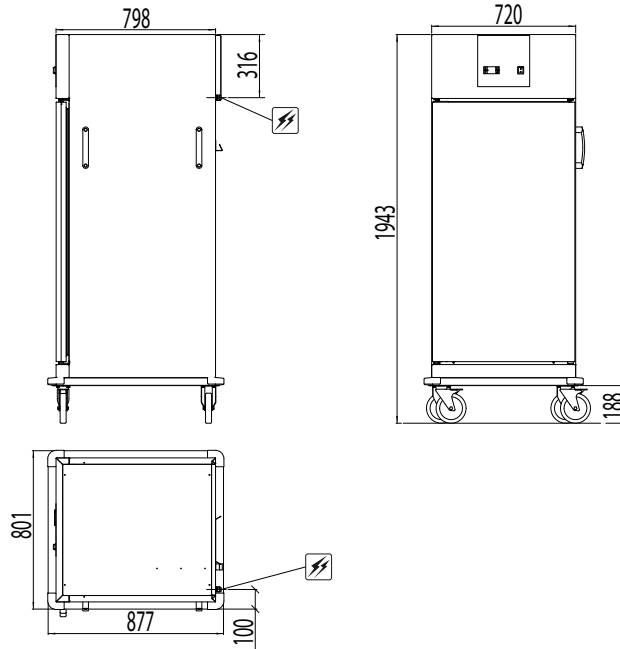

Overall dimensions
(W x D x H) - mm

801 x 877 x 1943h

Trays capacity

16 x GN 2/1
32 x GN 1/1

Distance
[mm]

68

Plates capacity

64 ø 200-260
32 ø 270-320

Power supply *

AC 230V 50Hz
AC 220-240V 50Hz

Climate class

5

Power *
[kW]

0,55
0,36

Amps. *
[A]

2,4
2,3

Cooling capacity *
[W]

445
590

Working
temperature [°C]

-18 ÷ 5

Product max
capacity [Kg]

96

Net weight
[Kg]

120

* Values are defined by the cooling unit of the machine

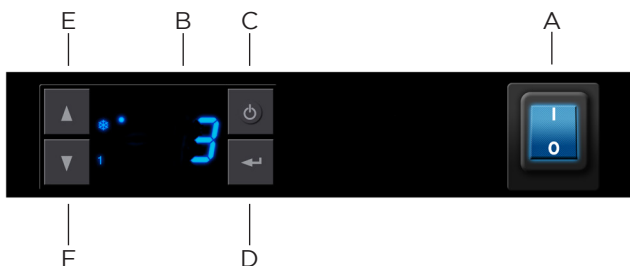

A ON/OFF switch

B Display

C Functions key

D Enter key

E Temperature increase key

F Temperature decrease key

MODULINESRL

Via dell'Industria 11, Z.I. San Giacomo di Veglia 31029 Vittorio Veneto (TV) - ITALY
tel. +39 0438 5063 - fax +39 0438 912 323 - info@moduline.it - www.moduline.it