

item #
model #
project #
sis #
aia #

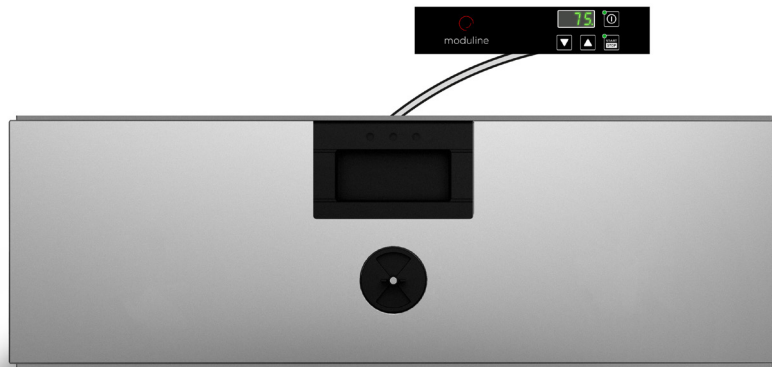

HOLD HSW011ER

Warm holding drawer,
built-in + remote control

CONSTRUCTION FEATURES

- Tightness chamber with radiused corners
- Total thermic insulation with rock or glass wool
- Long lasting drawers seals made up of food grade of high heat resistance
- Static heating provided by low consumption wire heating element that coils up all the chamber
- Ergonomic and fully built-in drawers handle with magnetic closure
- Built-in version with remote controls

FUNCTIONAL FEATURES

- Electronic control of the temperature
- Operating temperature 30° ÷ 120°C
- Humidity vents
- Chamber with safety thermostat
- Manual keyboard lock

STANDARD SUPPLY

- Removable GN1/1 tray racks

OPTIONS & ACCESSORIES

- Grids
- Trays
- Black colour
- Built-in frame

MODULINESRL

Via dell'Industria 11, Z.I. San Giacomo di Veglia 31029 Vittorio Veneto (TV) - ITALY
tel. +39 0438 5063 - fax +39 0438 912 323 - info@moduline.it - www.moduline.it



moduline

TECHNICAL INSTALLATION DIAGRAM

Electricity supply
cable inlet 

Humidity
exhaustion vent 

Important - Drawing and dimensions refer to the standard version. They may change with the addition of accessories or options.

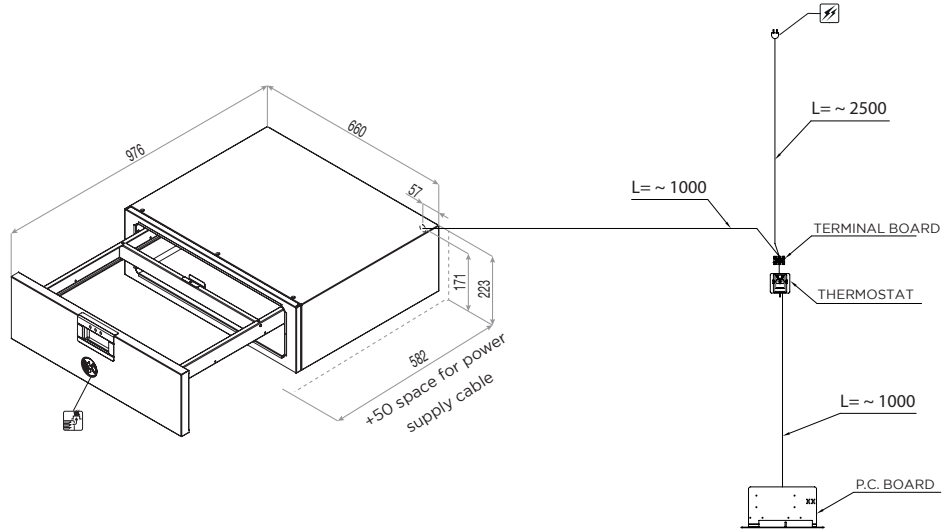

Overall dimensions
(W x D x H) - mm

660 x 582 x 223h

Power supply

AC 220-240V 50/60Hz

Total input
[kW]

0,7 (230V)

Amps.
[A]

3,1 (230V)

Working temperature [°C]

30 ÷ 120

Trays capacity

1 GN 1/1

Containers max height [mm]

150

Product max capacity [Kg]

6

Net weight [Kg]

31

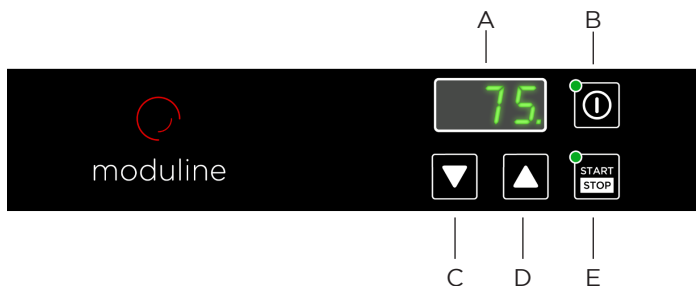

- A Display
- B ON/OFF switch
- C Temperature decrease key
- D Temperature increase key
- E START/STOP key

MODULINESRL

Via dell'Industria 11, Z.I. San Giacomo di Veglia 31029 Vittorio Veneto (TV) - ITALY
tel. +39 0438 5063 - fax +39 0438 912 323 - info@moduline.it - www.moduline.it