



# COOK&HOLD CHC082E

Static low temperature  
 oven

**CONSTRUCTION  
 FEATURES**

- Tightness chamber with radiused corners
- Total thermic insulation with rock or glass wool
- Long lasting frontal seals made up of food grade of high heat resistance
- Static heating provided by low consumption wire heating element that coils up all the chamber
- Snap-shut door
- Four whell, two of which with brake
- All-around rubber bumpers
- Tightness cavity with radiuses corners, built-in drip tray and drainage system

**FUNCTIONAL  
 FEATURES**

- Electronic control panel of temperature, time, core probe and  $\Delta t$  with LCD 4,3"touch-screen
- Operating temperature 30°C – 160°C
- End-of-cycle buzzer
- Chamber with safety thermostat
- Internal drain for easy cleaning
- Condensation drain tray
- Start timer programmed

**STANDARD  
 SUPPLY**

- Multipoint core probe with the possibility to register 30 different temperatures and save them in the HACCP report
- Glazed door plus lighting
- Removable GN 2/1 and GN 1/1 tray racks
- USB port saving device HACCP

**OPTIONS  
 & ACCESSORIES**

- |   |  |
|---|--|
| <input type="checkbox"/> EcoWash self-cleaning system | <input type="checkbox"/> Trays   |
| <input type="checkbox"/> Opposite side opening        | <input type="checkbox"/> Water filter system (together with washing)     |
| <input type="checkbox"/> Grids                        | <input type="checkbox"/> Detergent/Rinsing agent (together with washing) |
| <input type="checkbox"/> UK plug                      |  |

**MODULINESRL**

TECHNICAL  
INSTALLATION  
DIAGRAM

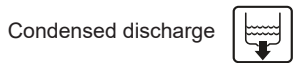
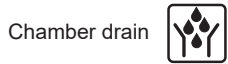
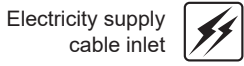

**Important** - Drawing and dimensions refer to the standard version. They may change with the addition of accessories or options.

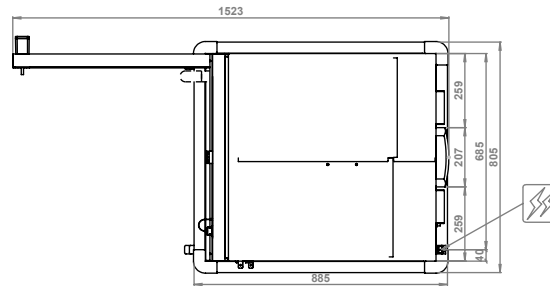
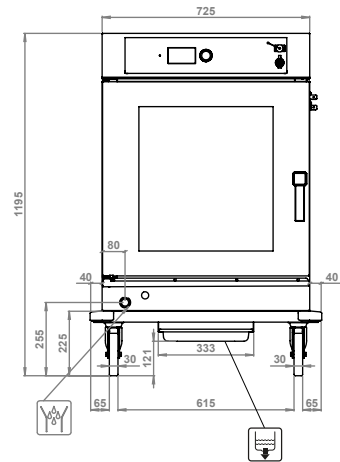
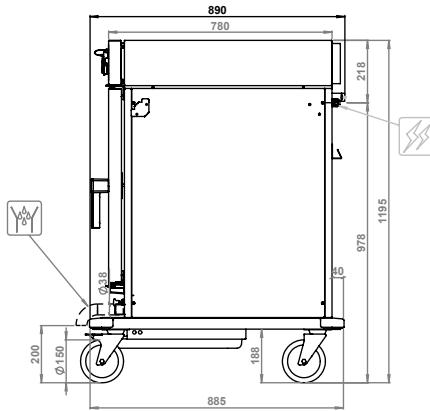

Overall dimensions  
(W x D x H) - mm 805 x 890 x 1195h

Power supply AC 220-240V 50/60Hz

Total input  
[Kw] 2,8 (230V)  
2,95 (230V) with Ecowash self-cleaning system

Amps.  
[A] 12,2 (230V)  
12,9 (230V) with Ecowash self-cleaning system

Working temperature  
[°C] 30 ÷ 160

Containers capacity -  
distance [mm] 8 GN 2/1 - (75)  
16 GN 1/1 - (75)

Product max capacity  
[Kg] 55

Net weight  
[Kg] 100

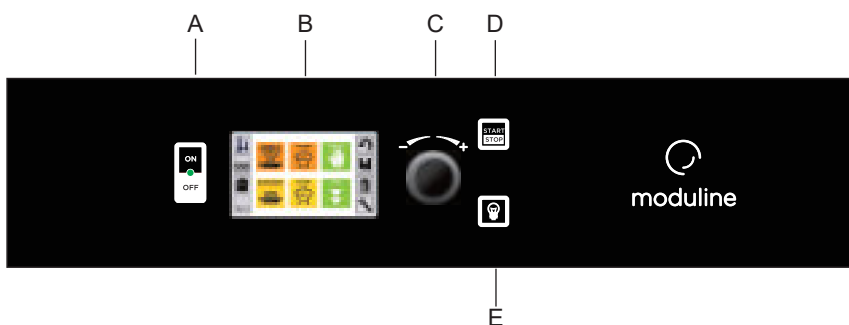

- A ON/OFF switch
- B Display Touch Screen
- C Setting knob and select "ENTER"
- D "START/STOP" button
- E Chamber light button

MODULINESRL

Via dell'Industria 11, Z.I. San Giacomo di Veglia 31029 Vittorio Veneto (TV) - ITALY  
tel. +39 0438 5063 - fax +39 0438 912 323 - info@moduline.it - www.moduline.it