

item #
 model #
 project #
 sis #
 aia #



COOK & HOLD CHT081K

Static low
 temperature oven

CONSTRUCTION FEATURES

- Tightness chamber with radiuses corners
- Rubber bumpers
- Total thermic insulation with rock or glass wool
- Silicone rubber door gasket resistant to heat and aging
- Removable side tray racks for easy cleaning
- Static heating provided by low consumption wire heating element DeliWarm® that coils up all the chamber
- Ergonomic and fully built-in door handle with magnetic closure
- Mounted on four 125 mm diameter castors, two of which with brake
- Ergonomic back handle for pushing and guiding
- Easy access to facilitate maintenance and repair

FUNCTIONAL FEATURES

- Capacitive control panel with temperature, probe, time, holding, and program management settings
- Operating temperature 30°-120°C
- Adjustable humidity vents on the door
- Chamber with safety thermostat
- Manual keyboard lock
- End of cycle buzzer

STANDARD SUPPLY

- Removable GN 1/1 tray racks
- Internal core probe

OPTIONS & ACCESSORIES

- Set of adjustable feet
- Grids
- Trays
- Reversible door
- UK plug
- Smoker
- WiFi

MODULINESRL



moduline

**TECHNICAL
INSTALLATION
DIAGRAM**

Electricity supply cable inlet 

Vent for excess humidity 

Important - Drawing and dimensions refer to the standard version. They may change with the addition of accessories or options.

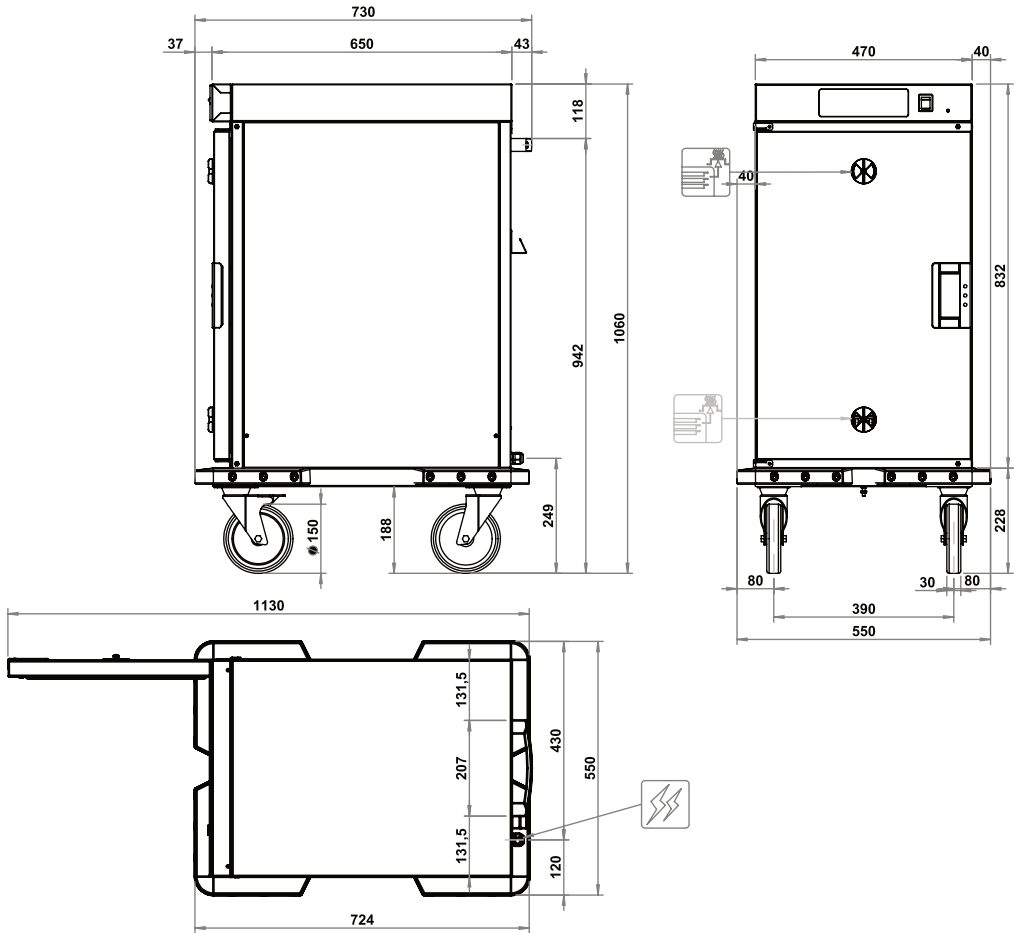

Overall dimensions (W x D x H) - mm	550 x 724 x 1060 h	Amps. [A]	4,4 (230V)
Trays capacity - distance [mm]	8 x GN 1/1 - (75)	Working temperature [°C]	30 ÷ 120
Tray max. height [mm]	8 x 65 (h) 3 x 150 (h) 2 x 200 (h) + 2 x 65 (h)	Product max capacity [Kg]	22
Power supply	AC 220-240V 50/60Hz	Net weight [Kg]	46
Total input [kW]	1 (230V)		



- A Chamber Temperature
- B Cooking time or by Probe
- C Holding Temperature or Holding by probe
- D Smoking (optional)
- E Programs (Save or Recall)
- F Increase value
- G Start / Stop
- H Decrease value
- I Info Display
- On/Off switch beside the board

MODULINESRL

Via dell'Industria 11, Z.I. San Giacomo di Veglia 31029 Vittorio Veneto (TV) - ITALY
tel. +39 0438 5063 - fax +39 0438 912 323 - info@moduline.it - www.moduline.it