



HOLD
HHT081E
 Warm holding cabinet

**CONSTRUCTION
 FEATURES**

- Tightness chamber with radiuses corners
- All-around rubber bumpers
- Total thermic insulation with rock or glass wood
- Long lasting front seal, made up of food-grade and high-heat resistant silicone
- Removable side racks to facilitate cleaning
- Static heating provided by low consumption wire heating element that coils up all the chamber DELIWARM®
- Ergonomic and fully built-in door handle with magnetic closure
- Four swivel wheels of which 2 with brake
- Ergonomic handle for pushing and guiding
- Easy access to facilitate maintenance and repair

**FUNCTIONAL
 FEATURES**

- Electronic control of the temperature
- Operating temperature 30°-120°C
- Adjustable humidity vents on the door
- Chamber with safety thermostat
- Manual keyboard lock

**STANDARD
 SUPPLY**

- Removable GN 1/1 tray racks

**OPTIONS
 & ACCESSORIES**

- Kit feet
- Grids
- Trays
- Opposite side opening
- UK plug
- Digital control with wi-fi

MODULINESRL

Via dell'Industria 11, Z.I. San Giacomo di Veglia 31029 Vittorio Veneto (TV) - ITALY
 tel. +39 0438 5063 - fax +39 0438 912 323 - info@moduline.it - www.moduline.it



moduline

TECHNICAL INSTALLATION DIAGRAM

Electricity supply
cable inlet 

Vent for excess
humidity 

Important - Drawing and
dimensions refer to the
standard version.
They may change with
the addition of
accessories
or options.

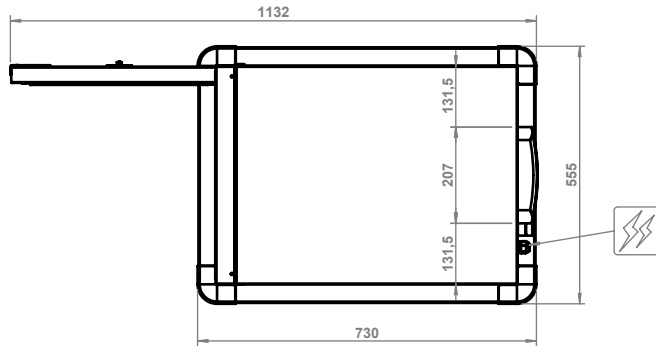
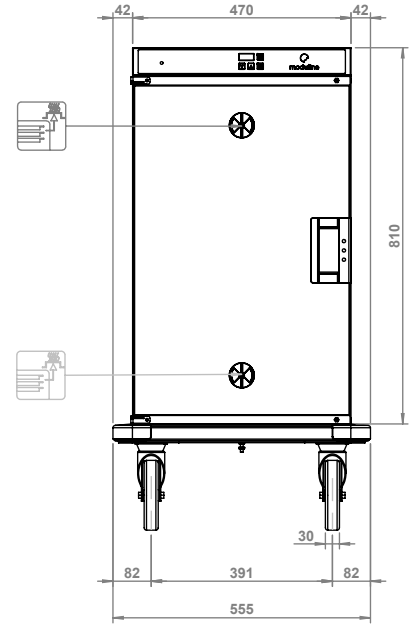
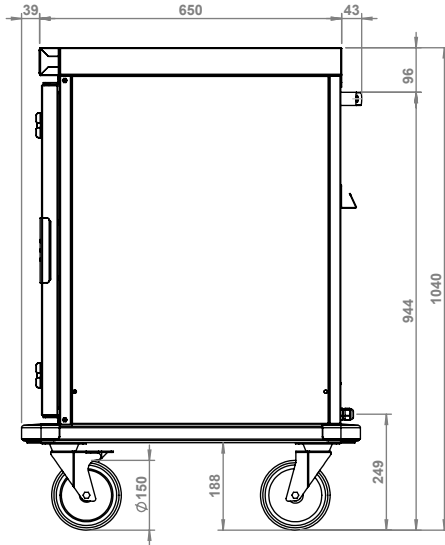

Overall dimensions
(W x D x H) - mm

555 x 730 x 1040 h

Amps.
[A]

4,4 (230V)

**Trays capacity -
distance [mm]**

8 x GN 1/1 - (75)

**Working
temperature [°C]**

30 ÷ 120

**Tray max. height
[mm]**

8 x 65 (h)
3 x 150 (h)
2 x 200 (h) + 2 x 65 (h)

**Product max
capacity [Kg]**

29

Power supply

AC 220-240V 50/60Hz

**Net weight
[Kg]**

46

**Total input
[kW]**

1 (230V)

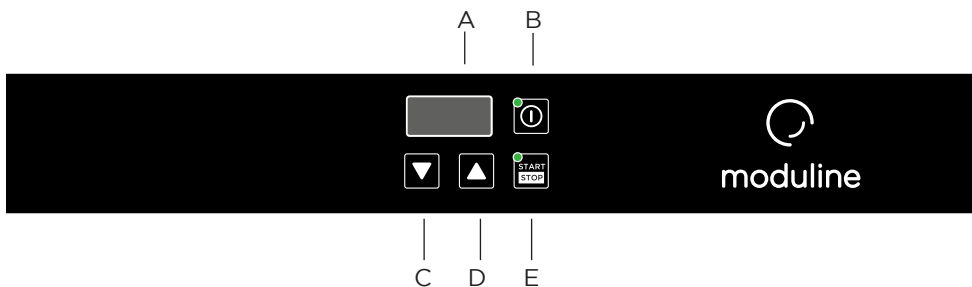

- A Display
- B ON/OFF switch
- C Temperature decrease key
- D Temperature increase key
- E START/STOP key

MODULINESRL

Via dell'Industria 11, Z.I. San Giacomo di Veglia 31029 Vittorio Veneto (TV) - ITALY
tel. +39 0438 5063 - fax +39 0438 912 323 - info@moduline.it - www.moduline.it